



ALSTOM - 2001 - Publication N° POWC/BPROB/ALSPA/uke/GDB/03.01/FR/1780 - ALSTOM, the ALSTOM and any alternative version thereof are trademarks and service mark of ALSTOM. The other names mentioned, registered or not, are the property of their respective companies. Photo: ALSTOM - Design: IGMATURE

**ALSTOM**

[www.alstom.com](http://www.alstom.com)

## ALSPA DRIVE RANGE

Drive solutions for all applications

**ALSTOM**

Power Conversion

## ALSTOM Power Conversion

### Extensive know-how

With extraordinary expertise in power conversion and an integrated global approach, ALSTOM meets the most stringent customer requirements for peak performance, reliable quality, and optimum profitability.

The company primarily operates in three complementary disciplines:

- Power conversion with control electronics, power-switching devices and drive systems using electric motors
- Automated process control in the electro-mechanical and electro-thermal industries
- Process engineering and modelling

### Specialisation

For ALSTOM engineers, a broad-based knowledge of electrical power management is complemented by in-depth experience and specialised expertise in seven specific areas:

- Metals Production & Processing
- Marine & Offshore
- Oil & Gas
- Electrical Conversion
- Mining and Materials Handling
- Process Industries
- Industrial Power Systems and all other industrial applications where drives are essential.

### Investing in the Future

ALSTOM Power Conversion invests more than five percent of its industrial control revenues in research and development to ensure that its products and technologies are always on the cutting edge, and that its power electronic and automation solutions are the most advanced in the world.

The R&D effort in automation, drive systems and power electronics is divided between a common development center in Paris and selected operating units in four countries.

Research in power electronics is handled by a dedicated ALSTOM power electronics research team.

Hardware and software products developed through this process are marketed under the ALSPA™ trademark. Each one benefits from ALSTOM's hands-on experience in the field, and from an ongoing commitment to the continued development of increasingly more competitive, more reliable, and more open solutions for higher performance.





## Drives

With more than 100 years of experience in installed drive power, ALSTOM is a recognised leader in the industry, providing reliable high-quality drives- produced at advanced manufacturing facilities in France, Germany, Great Britain, and the United States- for all industrial sectors in most countries of the world.

ALSTOM's broad product line ranges from simple off-the-shelf low voltage drives at only 0.25kW, up to the largest available engineered drives of over 100MW. And, because the company incorporates its own drives into other manufactured equipment and systems, years of user experience

addition, manufactures large motors and generators.

Recent innovations in drive solutions include: a new type of electric propulsion that mounts the motor in an under-ship pod; a 19MVA, 4.2kV an IGBT propulsion converter and motor for electric warship; 100MVA converters for pumped storage systems; and 15MVA, 50Hz, three phase to single phase traction supply converters with Active Energy Management.

For systems integrators, who need high-quality drive components to build into their own drive solutions,

drives with sinusoidal current return to the mains supply, to a medium voltage drive up to 10kV output without any transformer- ALSTOM's drive range provides the solution. And for special drive applications, customised products and solutions are available on request.

### Standardised Equipments

DC drives from 7.5kW to 25MW (customised drives above 750kW)

AC drives for low voltage induction motors from 0.25kVA to 5MVA

AC drives for medium voltage induction motors from 300kVA to 25MVA

AC drives for synchronous or wound rotor motors from 0.25kW to 100MVA

Applications include:

- ✚ Cement mills, crushers
- ✚ Compressors
- ✚ Conveyors
- ✚ Cranes
- ✚ Extruders, mixers
- ✚ Fans and pumps
- ✚ Machine tools
- ✚ Marine propulsion
- ✚ Metal rolling mills
- ✚ Mine hoists
- ✚ Paper making
- ✚ Presses
- ✚ Process lines
- ✚ Rolling roads
- ✚ Test benches
- ✚ Wind tunnels
- ✚ Wind turbines

have guided the development of every one.

ALSTOM also provides complete system design and engineering services, including automation and total project management, and, in

ALSTOM's range of drives also includes low voltage drive modules, inverters, and rectifiers up to 3.6MW.

From simple to complex requirements from 200V fans or pump drives of a few kilowatts, to large conveyor

## Controls

### Innovative Concepts

To satisfy the diverse requirements of its extensive range of available speed drives, ALSTOM has a range of controllers available from 16-bit, fixed point, embedded software versions to 32-bit floating point versions.

ALSTOM recently developed a new power electronic controller family (PEC) that ranges from single card units (standard or advanced) for products and small systems to modular, rack based arrangements, suitable for the most complex applications. ALSTOM has embarked on a programme to make the PEC family available for all of its solutions.

The advantages that the PEC family will bring to the user are numerous, some features are highlighted below.

### Common Programming Tools for all Drives and Automation

The new PEC family provides a single architecture for all drives in which the essential features are implemented using common technologies, including:

- ✚ Pentium class processor operating at 32-bit with floating point calculations
- ✚ Common operating system, used by both drives and automation
- ✚ IEC 61131-3 programming with Function Block Diagram as the core language

- ✚ Common control structure built from a common library of function blocks
- ✚ Common programming tools
- ✚ Common HMI systems
- ✚ Communication interfaces including all popular fieldbuses
- ✚ All hardware, software and communication interfaces based upon industry standards

### Flexibility and Options

Optional features can extend the functionality of all controllers in the family:

- ✚ Enhancement processors Pentium class or digital signal processor DSP
- ✚ Extendable user I/O
- ✚ Fieldbus options including WorldFIP, Profibus, Interbus, Ethernet, etc

### Diagnostics and History Records







Because the entire controller family is fully integrated, diagnostics is significantly enhanced.

All controllers in the range offer:



- ✚ Extremely powerful yet flexible history recording to enable analysis after a fault condition. The data is exportable to common file formats for analysis by third party tools
- ✚ Extensive status monitoring of alarms, trips, and user defined events
- ✚ Tele-diagnostics / Tele-maintenance

Diagnostics data can be viewed or extracted using one of several common tools, including a Drive Data Manager™ keypad, a PC based visualisation package, or a central programming console (for a large system).

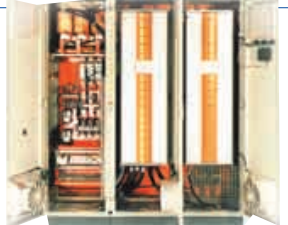
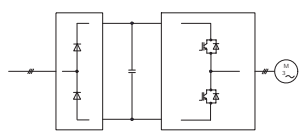
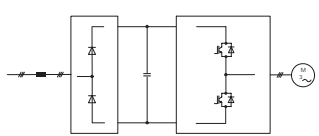
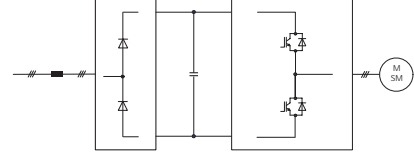
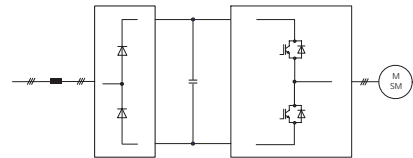
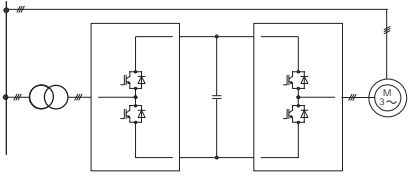
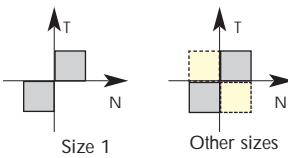
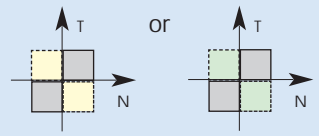
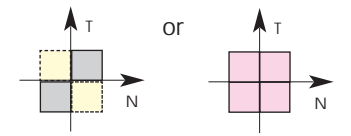
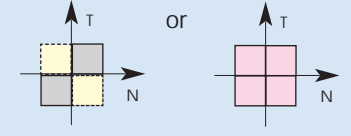
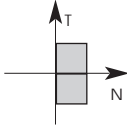
# LOW VOLTAGE AC DRIVES



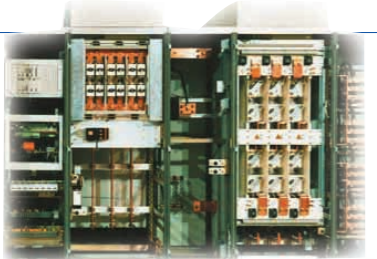

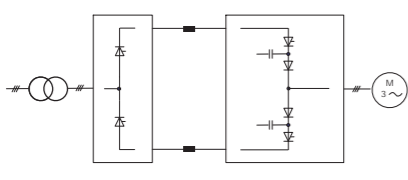
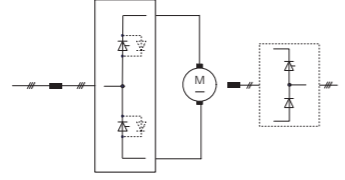
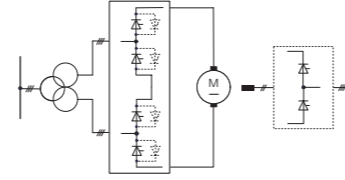
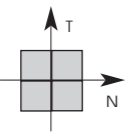
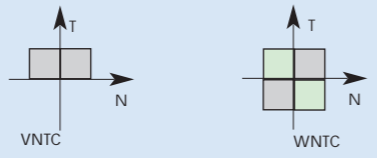
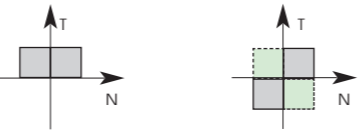





Product	MV500	MV1000	MV3000 Microcubicle™	MD2000 Built-in-Units	MV3000 DELTA* Cubicle Mounted	MD 2000 Cubicle Mounted	Double Fed Low Voltage Drive
Typical view							
Type of Drive	VSI-2L Flux vector open control loop 2 level	VSI- 2L Open and closed loop flux vector control or VVVF <sup>3</sup> -2 level	VSI- 2L Open and closed loop flux vector control or VVVF <sup>3</sup> 2 level		VSI- 2L Open and closed loop flux vector control or VVVF <sup>3</sup> 2 level		DFM - LV Low Voltage VSI in the rotor Stator connected to fixed low voltage supply
Principle circuit diagram							
Network / Machine	D/IGBT	D/IGBT	D/IGBT or IGBT/IGBT - Can also be DC fed		D/IGBT or IGBT/IGBT - Can also be DC fed		IGBT/IGBT
Features Benefits and Applications	Compact equipment, simple installation and commissioning Extra menus for complex applications: PID, etc	Versatile drive with high features and flexibility Control common to MD2000	Small size, high features Easy to install in stand alone form and small systems	Drive with control software common to MV1000 for use in system applications	Modular version for cubicle mounting. Available in both air and water cooled versions	Air cooled cubicle mounted version for higher power and system applications	Economical solution for small speed range Wind generator applications
Quadrants							
Rated Power	220Vac: 0.25kW to 7.5kW 400Vac: 0.75kW to 15kW	0.75kW to 45kW	22kW to 315kW	18.5kW to 280kW	Air: up to 1500kW Water: up to 3600kW	Air: up to 4500kW	Stator: 0.5MVA to 3MVA Rotor: 0.15MVA to 2MVA
Input Voltage	220Vac single and three-phase 380Vac - 480Vac three-phase	380Vac - 480Vac	380Vac - 690Vac		380Vac - 690Vac		380Vac - 690Vac
Output Voltage	0 to supply voltage	0 to supply voltage	0 to supply voltage or more with AEM <sup>2</sup>		0 to supply voltage or more with AEM <sup>2</sup>		380Vac - 690Vac
Rated Current	1.5A to 28.5A (220Vac) 2.1A to 30.5A (400Vac)	2.5A to 89A (400Vac)	40A to 565A	40A to 483A	Air: up to 2760A Water: up to 3860A	Air: up to 4860A	250A to 2000A
Typical Speed Range	50/1	Closed loop: 1000/1 Open loop: 100/1 VVVF <sup>3</sup> : 100/1	0 to 200Hz		0 to 200Hz		70-100 % of synchronous speed
Max Output Frequency	1000Hz	400Hz	400Hz		400Hz		50Hz (60Hz) 16Hz: typical for wind generators
Field Weakening	≥ 3:1	≥ 3:1	≥ 4:1		≥ 4:1		Not relevant
Options <sup>1</sup>	Braking resistors Keypad	Expansion I/O block Braking / Regenerative unit Keypad	12 pulse, AEM <sup>2</sup> , Common DC bus, Dynamic Braking Resistors, Supply Filters Keypad		12 pulse, 18 pulse, 24 pulse, AEM <sup>2</sup> , Common DC Bus, Dynamic Braking Resistors, Supply Filters Keypad		Air or water cooled Customised solutions
Motor Type	Induction motor	Induction motor	Induction motor		Induction motor		Wound rotor motor

# DC DRIVES



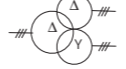

Product	CDL8000	VNTC / WNTC	Large DC Drives
Typical view			
Type of Drive	CSI Current source inverter with forced commutation by capacitors	DC drives	LDCD
Principle circuit diagram			
Network / Machine	6 thyristor bridge in series or parallel according to power. No reverse bridge required for 4Q operation	VNTC: 6 thyristor bridge WNTC: 2 antiparallel 6 thyristor bridges	6 thyristor bridge in single-way or antiparallel connection and several bridges connected in series or parallel according to power
Features, Benefits and Applications	Robust drive, short circuit proof, with natural-braking capability suitable for mining, coal crushers, desulphurisation plants, soft-starting of large induction motors	For low voltage DC motor applications Regeneration to the mains (WNTC)	Retrofit for existing DC Motors
Quadrants			
Rated Power	1MW to 5.4MW	7.5kW to 750kW	1MW to 25MW
Input Voltage	0.4kV to 10kV (transformer)	380Vac to 660Vac	0.4kV to 10kV (transformer)
Output Voltage	400Vac - 690Vac - 800Vac	440Vdc to 750Vdc	0.8 to 2kVdc
Rated Current	700A to 4000A	25A to 1850A	2000A to 12000A
Typical Speed Range	50/1	100/1	1000/1
Max Output Frequency	200Hz	Not relevant	Not relevant
Field Weakening	1.2:1	4:1 with field control built in	3:1
Options <sup>1</sup>	12 pulse Synchronous transfer to mains	Expansion I/O block and serial port Additional processor for customised functions and standard function library	Regeneration on the mains Air or water cooled Customised solutions
Motor Type	Induction motor	DC motor separately excited	DC motor

## Charts

### Icon symbols designed according to IEC standard 617-6

-  Diode D
-  GTO Thyristor GTO
-  Thyristor Thy
-  IGBT (Transistor) IGBT
-  DC Motor
-  3 Phase Synchronous Motor
-  3 Phase Induction Motor
-  3 Phase Wound or Slipring Motor
-  3 Phase Transformer with 1 delta secondary 1 star secondary
-  3 Phase Transformer
-  Choke

### Motor quadrant symbols according to IEC 61800-2

-  Basic use
-  Braking by resistor
-  Braking with regeneration to the mains
-  Active Energy Management (AEM<sup>2</sup>)
-  Optional





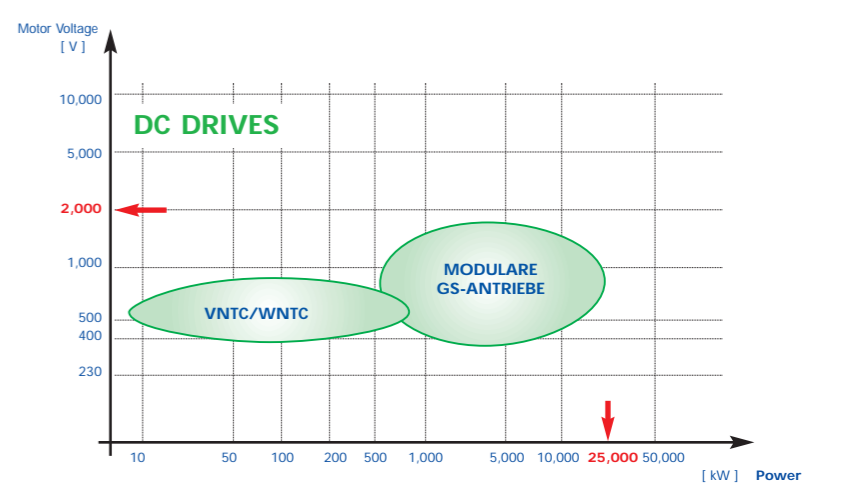
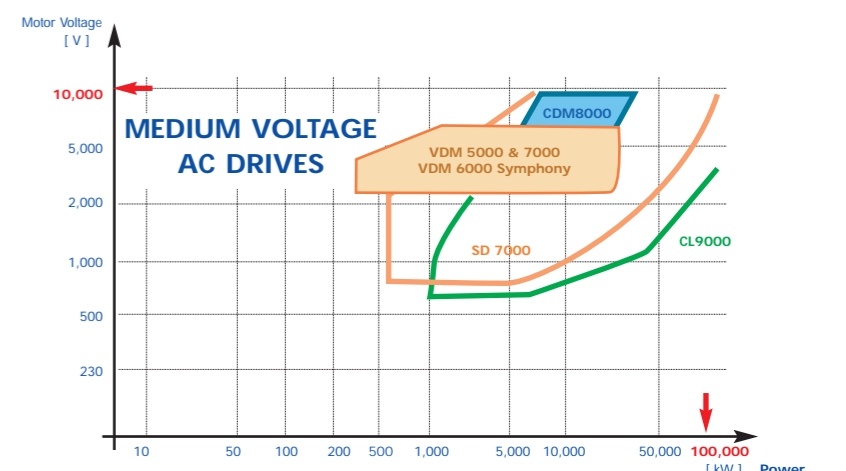
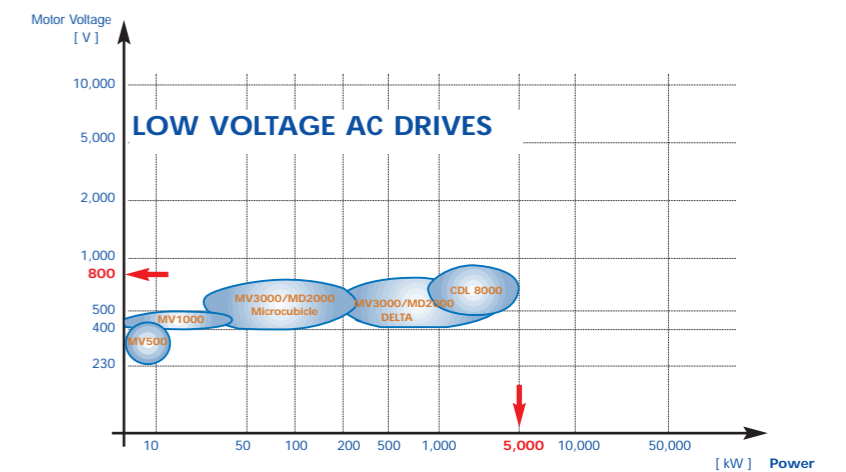

### Abbreviations

- 1 PC programming and commissioning tools  
Popular fieldbus available for each drive type:  
WorldFip, Profibus DP, Device Net, Modbus, CANOpen
- 2 AEM: Active Energy Management, also takes/regenerates a sinewave current from/to the supply
- 3 VVVF: Variable Voltage - Variable Frequency
- \* DELTA: Modular construction supplied as a kit or as a complete drive cabinet
- AP Antiparallel converter
- D/IGBT Diode rectifier / IGBT inverter
- D/GTO Diode rectifier / GTO Thyristor inverter
- THY/IGBT Thyristor converter / IGBT inverter
- THY/THY Thyristor converter / Thyristor inverter
- THY/GTO Thyristor converter / GTO Thyristor inverter
- GTO/GTO GTO Thyristor converter / GTO Thyristor inverter
- IGBT/IGBT IGBT converter / IGBT inverter





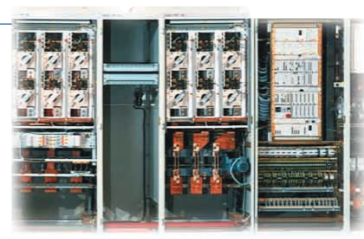

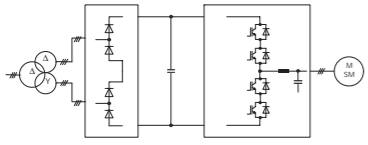
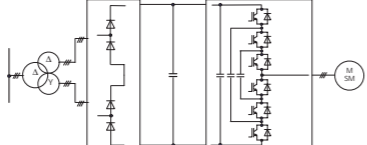
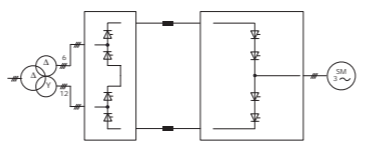
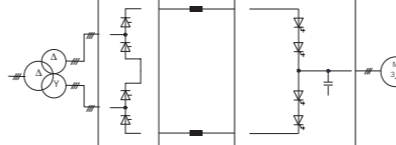
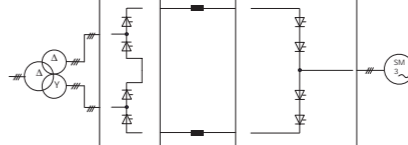
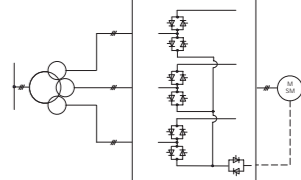
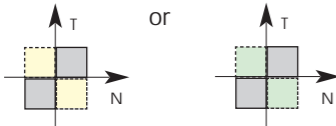
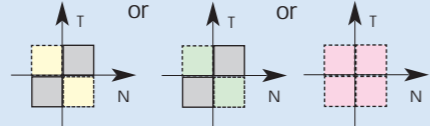
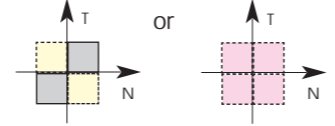
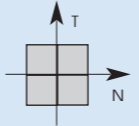
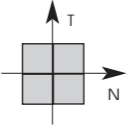
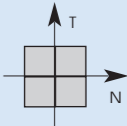
# MEDIUM VOLTAGE AC DRIVES

Product	VDM5000	VDM6000 Symphony	VDM7000	CDM8000	SD7000	CL9000
Typical view						
Type of Drive	VSI-2L Voltage Source Inverter 2 level	VSI-ML Voltage Source Inverter Multilevel	VSI-NPC Voltage Source Inverter Neutral Point Clamped	CSI Current Source Inverter	LCI Load Commutated Inverter	CC Cyclo Converter
Principle circuit diagram						
Network/ Machine	D/IGBT: 6,12,18 pulse converter Thy/IGBT: 6,12,18 pulse converter IGBT/IGBT with AEM <sup>2</sup> converter Can also be DC fed	D or Thy/IGBT:6,12,18 pulse converter Thy/IGBT:12 pulse AP converter IGBT/IGBT with AEM <sup>2</sup> converter Can also be DC fed	D/GTO: 6,12, 18 pulse Thy/GTO: 6,12 pulse AP converter GTO/GTO with AEM <sup>2</sup> converter Can also be DC fed	Thy/GTO: 6, 12 pulse converter GTO/GTO: with AEM <sup>2</sup> converter	Thy/Thy: 6, 12, 24 pulse converter	Thy (No intermediate link)
Features, Benefits and Applications	Short circuit proof without fuses Sinewave output with low harmonic content through sinusoidal filter Water cooled No motor derating Marine applications	World leading patented technology Short circuit proof without fuses Sinewave output through multilevel technology Air and water cooled No motor derating All Industries and Marine	Robust water cooled drive with high dynamic performance for large power, short circuit proof, no motor derating, hot and cold rolling mills and mains coupling systems, 50Hz/16 <sup>2</sup> / <sub>3</sub> Hz	Robust water cooled drive for high speed and big power applications Short circuit proof without fuses Natural braking capability Sinewave output due to CSI characteristics No motor derating	High power drive solution for synchronous motor with low dynamic performance, simple braking capability due to CSI characteristics Static frequency converter for starting large machines Propulsion drives, boiler feed pumps Extruders, pumps, fans, blowers Conveyors, pump storage schemes,	Conventional solution for high power, low speed, high overload capability, high dynamic performance, low torque ripple, natural braking capability Low speed drives for metal, cement, mine industries Propulsion: icebreakers Rotor converters in power supply generators
Quadrants						
Rated Power	1.4MVA to 7.2MVA	Air: 0.3MVA to 3MVA Water: 2.2MVA to 8MVA	7MVA to 9.5MVA	5MVA to 8MVA   8.3MVA to 13.5MVA	Air: 2MVA to 10MVA Water: 5MVA to 100MVA	Air: 2MVA to 12MVA Water: 5MVA to 100MVA
Input Voltage	2.3kV to 13.8kV (transformer). Up to 4.16kV without transformer	2.3kV to 13.8kV (transformer) 4.2kV (air), 3.3kV (water) without transf	2.3kV to 13.8kV (transformer) Up to 3.3kV without transformer	2.3kV to 13.8kV (transformer) Up to 10kV without transformer	2.3kV to 13.8kV (transformer) Up to 10kV without transformer	2.3 kV to 13.8kV (transformer)
Output Voltage	2.3 - 3.3 - 4.2kV	2.3 - 3.3 - 4.2kV	3.3kV	6kV   10kV	1kV to 10kV	Air: 1kV to 4kV Water: 1kV to 5kV
Rated Current	Up to 1000A	Air: up to 300A Water: up to 800A	Up to 1600A	480A   770A	Air: 1200A (1kV) to 1500A (4kV) Water: 3000A (1kV) to 6000A (10kV)	Air: 1200A to 3000A (1kV) Water: 3000A (1kV) to 12000A (5kV)
Typical Speed Range	With encoder: 1000/1 Encoderless: 50/1	With encoder: 1000/1 Encoderless: 50/1	With encoder: 1000/1 Encoderless: 50/1	With encoder: 1000/1 Encoderless: 50/1	10 - 100%	0 - 100% (600 rpm for 4-pole motor)
Max Output Frequency	130Hz	Air: 60Hz Water: 130Hz	60Hz	240Hz	100Hz (60Hz)	25Hz
Field Weakening	5:1 with synchronous motors 3:1 with induction motors	5:1 with synchronous motors 3:1 with induction motors	5:1 with synchronous motors 3:1 with induction motors	1.2:1	1.1:1	5:1 with synchronous motors 3:1 with induction motors
Options	200Hz output frequency 11MVA-6.6kV (tandem configuration) Supply regeneration-AEM <sup>2</sup> Dynamic braking thyristors	Freq output: air: 120Hz - water: 200Hz 9.2MVA-6.6kV (water cooled tandem configuration) Supply regeneration-AEM <sup>2</sup>	200Hz 18MVA (2 in parallel) 6.6kV (tandem configuration) Supply regeneration-AEM <sup>2</sup>	400Hz 25MVA (2 in parallel) Operation in parallel with thyristor converter	Customised	Customised
Motor Type	Medium voltage synchronous and induction motors	Medium voltage synchronous and induction motors	Medium voltage synchronous and induction motors	Medium voltage induction motor	Synchronous motor	Synchronous motor or wound rotor motor or induction motor

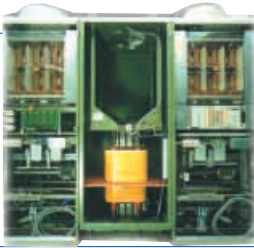
# CUSTOMISED DRIVES FOR DEDICATED APPLICATIONS

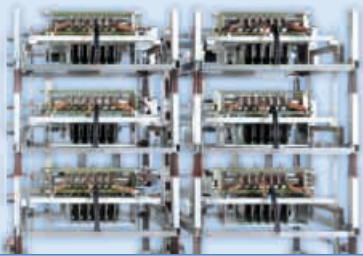
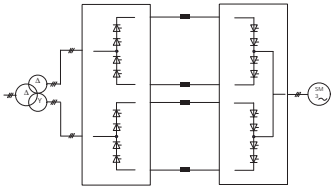
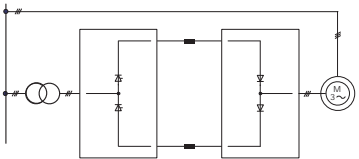
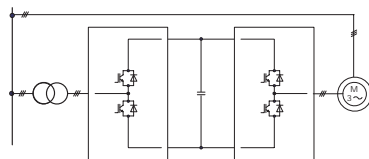
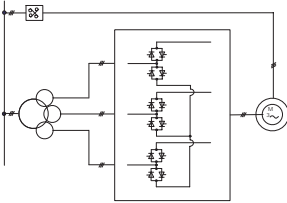
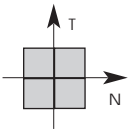
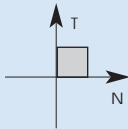
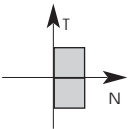
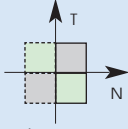
Product	CC/LCI	SsCc	DFM - VSI	DFM - CC
Typical view				
Type of Drive	CC / LCI Cyclo Converter combined with LCI	Ss Cc Subsynchronous Converter cascade with slip energy recovery Stator connected to fixed MV supply	DFM - VSI Double fed motor with VSI in the rotor Stator connected to fixed MV supply	DFM - CC Double fed motor with CC in the rotor Stator connected to fixed MV supply
Principle circuit diagram				
Network / Machine	Thy/Thy	Rotor: Thy/D 6 pulse converter	Rotor: IGBT / IGBT	Rotor: Thy (No intermediate link)
Features, Benefits and Applications	Extended conventional CC-solution for high power, medium speed, high overload capability, high dynamic performance, low torque ripple, natural braking capability Drives for metal, mine industries	A conventional solution for high power and limited speed range Low voltage converter in the rotor Power generation: Boiler feed pumps	Economical solution in this power range with limited speed range Low voltage converter in the rotor Used with wind power generators	Economical solution for extremely high power with limited speed range and for slip frequencies <20Hz Based on conventional components Power generation: pumped schemes storage plants Mains coupling systems
Quadrants				 Optional quadrant by changeover switchgear in stator
Rated Power	Air: 2MVA to 6MVA Water: 5MVA to 20MVA	Stator: 5MVA to 20MVA Rotor: 2MVA to 10MVA	Stator: 1MVA to 8MVA Rotor: 0.4MVA to 3MVA	Stator: 50MVA to 300MVA Rotor: 20MVA to 100MVA
Input Voltage	2.3kV to 13.8kV (transformer)	2.3kV to 13.8kV (transformer)	2.3kV to 13.8kV (transformer)	10kV to 20kV
Output Voltage	Air: ≤ 2kV Water: 2.3kV to 5kV	Stator: 3kV to 20kV Rotor: ≤ 2kV	Stator: 3kV to 10kV Rotor: ≤ 1kV	Stator: 10kV to 20kV Rotor: 1kV - 5kV
Rated Current	Air: 600A to 1700A Water: 1500A to 6000A	Rotor: 5000A	Rotor: 600A to 1700A	Rotor: 6000A to 12000A
Typical Speed Range	0 - 100 % (up to 1800 rpm for 4-pole motor)	70 - 100 %	70 - 100%	70 - 100%
Max Output Frequency	75Hz	50Hz (60Hz) Rotor: typically 16Hz max.	Rotor: typically 16Hz max. for wind generator	Rotor: typically 20Hz max.
Field Weakening	5:1	Not relevant	Not relevant	Not relevant
Options	Customised	Customised	Customised	Customised
Motor Type	Synchronous motor	Wound rotor motor	Wound rotor motor	Wound rotor motor

## Additional capabilities

### POWER SUPPLY PLANTS

**DC power supply** and high current rectifier systems. A complete range for electrolysis processes, arc furnaces and other applications. Ratings of more than 60,000 amps per 12-pulse bridge are available, based on direct water-cooled converter cubicles. Typical data for aluminium smelter plants are between 4 x 60kA and 5 x 70kA at 1000Vdc. Many successfully operating references all over the world.

**AC power conversion** systems up to 100MVA based on static frequency converter units used in many different applications, such as:

- ✦ Converters and frequency inverters for feeding large magnets in fusion research institutes
- ✦ Frequency converters for AC/AC conversion (3AC /1AC, 50/16 <sup>2</sup>/<sub>3</sub>Hz; 60/20Hz); as turn-key standard systems converting 110kV 50Hz into 25kV 16<sup>2</sup>/<sub>3</sub> Hz as developed for Deutsche Bahn Energie.

### POWER QUALITY SYSTEMS

A range of solutions to provide high power quality:

- ✦ ALSTOM PQS line  
Static VAR compensation systems for flicker compensation, and power factor correction for arc furnaces and other applications  
air cooled up to 22MVAR  
water cooled up to 400MVAR
- ✦ Energy storage systems >4MW for super-conducting magnetic coils
- ✦ ALSPA PQA line:  
Active filtering systems

## Customer support

ALSTOM is committed to an exceptionally high level of customer support services. Its corporate philosophy is based on the premise that customer relationships are only just beginning when systems are commissioned, and that lifetime support is vital for long term success.

ALSTOM's worldwide service organisation works closely with its clients to improve their business performance by ensuring optimum operation of plant and systems with increased availability and improved system performance. And, because specific needs vary from industry to industry, the structure and operation of the company's service organisation are adapted accordingly.

ALSTOM offers a full portfolio of support services that can also be tailored to individual requirements.

These include:

- ✦ 24 hours telephone helpline
- ✦ Emergency breakdown call-out
- ✦ Remote diagnostic facilities
- ✦ Service and maintenance contracts
- ✦ Spare parts supply and inventory management
- ✦ Obsolescence management
- ✦ Training centres
- ✦ Maintenance engineering
- ✦ Plant and system optimisation
- ✦ Upgrades and enhancements

### Worldwide presence

A network of operating locations around the world ensures that ALSTOM shares the cultural and geographic identity of each and every customer. In addition, each location serves as a conduit for the global resources of the entire ALSTOM organisation.

Anywhere in the world, ALSTOM is just a phone call away.

For more information, please visit the Web site.

ALSTOM Power Conversion

#### France

3, avenue des Trois Chênes  
90018 Belfort Cedex  
Tel: +33(0) 3 84 55 16 48  
Fax: +33(0) 3 84 55 20 65

9, rue Ampère  
91345 Massy Cedex  
Tel: +33(0) 1 60 13 24 43  
Fax: +33(0) 1 60 13 20 02

#### Germany

Culemeyerstraße 1  
D- 12277 Berlin  
Tel: +49(0) 30 74 96 27 00  
Fax: +49(0) 30 74 96 27 08

#### UK

Boughton Road, Rugby  
Warwickshire, CV21 1BU  
Tel: +44(0) 1788 563 563  
Fax: +44(0) 1788 560 767

#### USA

610 Epsilon Drive  
Pittsburgh, PA 15238  
Tel: +1 412 967 0765  
Fax: +1 412 967 7660

[www.powerconv.alstom.com](http://www.powerconv.alstom.com)